

**R18**

**Code No: 152AG**

**JAWAHARLAL NEHRU TECHNOLOGICAL UNIVERSITY HYDERABAD**

**B. Tech I Year II Semester Examinations, January/February - 2024**

**ENGINEERING GRAPHICS  
(Computer Science and Engineering)**

**Time: 3 Hours**

**Max. Marks: 75**

**Answer any five questions  
All questions carry equal marks**

---

- 1.a) A line 10 cm long represents a distance of 5 m. Construct a diagonal scale to read up to 10 m, showing metres decimeters and centimeters. Show the length 8.49m on the scale.  
b) Draw a hyperbola when the distance between its focus and directrix is 50mm and eccentricity is  $3/2$ . [7+8]

**OR**

2. Draw an epi cycloid with the radius of the generating/rolling circle and radius of the directing circle equal to 30 mm and 100 mm respectively. Draw normal and tangent to the curve at any point on the epi cycloid curve. [15]
3. A line AB, 65 mm long has its end A 20 mm above the H.P. and 25 mm in front of the V.P. The end B is 40 mm above the H.P. and 65 mm in front of the V.P. Draw the projections of AB and show its inclinations with the H.P. and the V.P. [15]

**OR**

4. Draw the projections of a regular pentagon of 40 mm side, having its surface inclined at  $30^\circ$  to the H.P. and a side parallel to the H.P. and inclined at an angle of  $60^\circ$  to the V.P. [15]
5. The hexagonal pyramid base 30 mm side and axis 60 mm long has one of its slant edges on HP such that two of its triangular faces containing the slant edge on which it rests are equally inclined to HP. The top view of the axis appears to be inclined at  $45^\circ$  to VP. Draw its projections when its base is nearer to the observer than its apex. [15]

**OR**

6. A hexagonal pyramid, base 30 mm side and axis 65 mm long, is resting on its base on the H.P. with two edges parallel to the V.P. It is cut by a section plane, perpendicular to the V.P. inclined at  $45^\circ$  to the H.P. and intersecting the axis at a point 25 mm above the base. Draw the front view, sectional top view and true shape of the section. [15]
7. A hexagonal prism of base side 30 mm and axis length 60 mm is resting on HP on its base with two of its vertical faces perpendicular to VP. It is cut by a plane inclined at  $50^\circ$  to HP and perpendicular to VP and meets the axis of prism at a distance 10 mm from the top end. Draw the development of the lateral surface of the prism. [15]

**OR**

8. Draw the development of a Cylinder of 40 mm diameter and 60 mm height, containing a square hole of 20 mm side. The sides of the hole are equally inclined to the base and the axis of the hole bisects the axis of the cylinder. [15]

QA

QA

QA

QA

QA

QA

QA

G

9. Draw the isometric view of the object whose orthographic projections are given in following figure 1. All dimensions are in mm. [15]

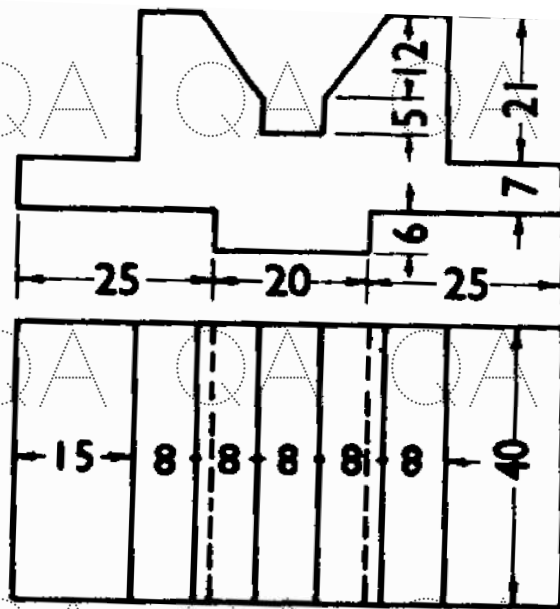

Figure 1

OR

10. Draw the front view, top view and left side of the given figure 2. (All dimensions are in mm) [15]

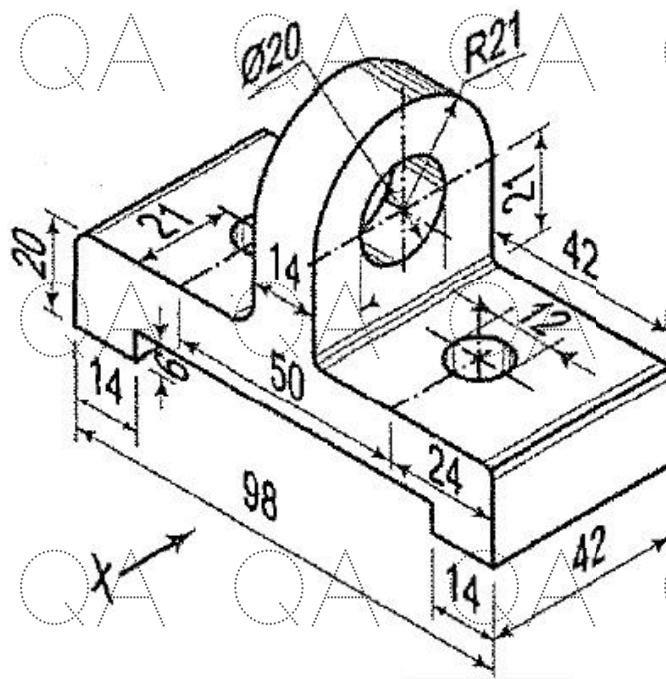

Figure 2

QA

QA

QA

---ooOoo---

QA

QA

QA

G